



1 Series

Capacity up to **75 lbs each**

SMALL TOP PLATE Swivel & Rigid



Standard Dimensions

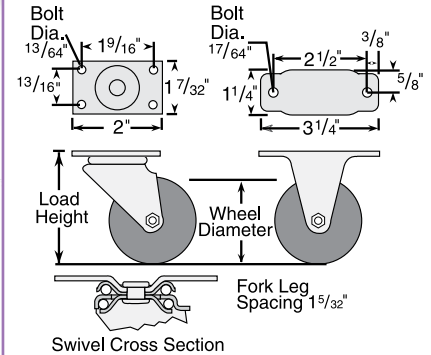

Features

- Zinc plated finish is attractive and durable
- Full double ball hardened raceways for better performance and greater durability
- 5/16" shouldered axle with 1/4" nut
- "Colson 45" multi-temp grease lubricates in extreme hot and cold temperatures

Standard Mounting

- Rigid caster mounting holes do not match swivel

Colson 1 Series Casters • Small Top Plate Swivel and Rigid • Capacity to 75 lbs each

Wheel Dia.	Tread Width	Capacity Each (Pounds)	Wheel Descriptions	Wheel Bearing	Swivel Top Plate Caster Models	Rigid Top Plate Caster Models	Load Height	Swivel Radius	Weight (Pounds)
1 5/8"	7/8"	60	Perma Rubber	Delrin	1.01666.441	1.01610.441	29/16"	1 3/4"	3/8
		75	Polyolefin	Delrin	1.01666.52	1.01610.52	29/16"	1 3/4"	3/8
2"	7/8"	75	Perma Rubber	Delrin	1.02266.441	1.02210.441	2 3/4"	1 15/16"	1/2
			Polyolefin	Delrin	1.02266.52	1.02210.52	2 3/4"	1 15/16"	1/2
			Cushion Rubber	Ball	1.02266.45	1.02210.45	2 3/4"	1 15/16"	1/2
			Hard Rubber	Ball	1.02266.55	1.02210.55	2 3/4"	1 15/16"	1/2
3"	7/8"	75	Perma Rubber	Delrin	1.03066.441	—	3 7/8"	29/16"	3/4
			Polyurethane HI-TECH	Delrin	1.03066.91	—	3 7/8"	29/16"	3/4
			Polyolefin	Delrin	1.03066.53	—	3 7/8"	29/16"	3/4

Caster Brake



Side Lock (See page 96)
Available on all 3" swivel models. Field installable (Specify **BRK3**; Example: 1.03066.91 BRK3).

Fork Options

NSF Listed for Food Service Industry
All models except thread guards.

Forks Only

To order caster forks only use 1st 6 digits of model numbers (Example: 1.01666).

Wheel Selection



See the Perma Advantage on Page 67.

Wheel Option

Thread Guards

(See page 108) Available on all 3" models. Brake & NSF options cannot be used with thread guards (Specify **TG1** for metal; Example: 1.01666.441 TG1).