

Floor Lock Brakes



Features

- Heavy duty industrial strength construction
- Durable, high-compression spring for heavy loads
- Foot pedal easily activates lock with foot pressure
- Conveniently located release bar retracts brake instantly with slight toe pressure to either side of the bar
- Non-slip, non-skid rubber brake pad holds securely on smooth or irregular floor. Designed for use on level surfaces.
- Attractive zinc plated finish

Top Plate Dimensions

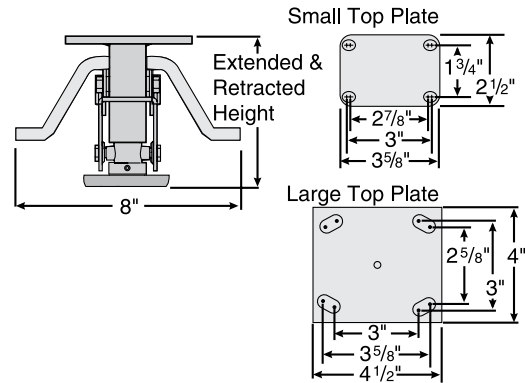

Floor Lock Brake Installation

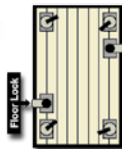

Recommended Floor Lock mounting position using four swivel casters.

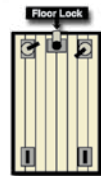

Recommended Floor Lock mounting position using two swivel and two rigid casters.

Colson Floor Lock Brakes are designed for use on level surfaces and are not recommended for use on inclined surfaces. It is important to select a floor lock model that clears the floor when retracted. To adapt a floor lock brake to your present equipment, select a model with an extended height 1/16" to 1/4" greater than the overall height of the caster.

Floor Lock Specifications

2 1/2" x 3 5/8" TOP PLATE MODELS (2 & 3 Series Casters)

MODEL NO.	9.06002.03	9.06253.04	9.06002.05
Extended Height A	4 ¹⁵ / ₁₆ "	5 ¹⁷ / ₃₂ "	6 ⁷ / ₃₂ "
Retracted Height B	3 ⁷ / ₈ "	4 ¹ / ₂ "	5 ¹¹ / ₆₄ "
Top Plate Size	2 1/2" x 3 5/8"		
Bolt Hole Spacing	1 3/4" x 2 7/8" to 3"		
Bolt Hole Size	5/16" Slotted		
Weight	2 3/4 lbs.	2 3/4 lbs.	2 3/4 lbs.
Used with Caster Fork Model Numbers	2.03208 2.03256 3.00308 3.00317	2.04208 2.04256 3.00408 3.00417	2.05008 2.05256

4" x 4 1/2" TOP PLATE MODELS (3, 4 & 6 Series Casters)

9.06045.04	9.06253.05	9.06045.06	9.06025.08
5 ⁷ / ₈ "	6 ⁴³ / ₆₄ "	7 ¹ / ₄ "	9 ²³ / ₃₂ "
4 ¹⁵ / ₁₆ "	5 ³⁵ / ₆₄ "	6 ²¹ / ₃₂ "	8 ⁵ / ₈ "
4" x 4 1/2"			
3" x 3" to 2 5/8" x 3 5/8"			
3/8" Slotted			
3 1/2 lbs.	4 1/2 lbs.	4 1/2 lbs.	4 3/4 lbs.
4.04108	3.00508	3.00608	4.08198
4.04109	3.00517	3.00617	4.08199
4.04408	4.05108	4.06108	4.08499
4.04409	4.05109	4.06109	4.08299
4.04189	4.05408	4.06408	4.08189
6.04208	4.05409	4.06409	6.08258
6.04209	4.05189	4.06189	6.08259
6.04279	6.05208	6.06208	6.08298
	6.05209	6.06209	6.08299
	6.05279	6.06258	
		6.06259	
		6.06299	



Easy to engage.



Easy to disengage.

Floor Lock Replacement Pad
34013.26