

2 Series

Capacity up to **325 lbs each**

STAINLESS STEEL Swivel & Rigid



Standard Dimensions

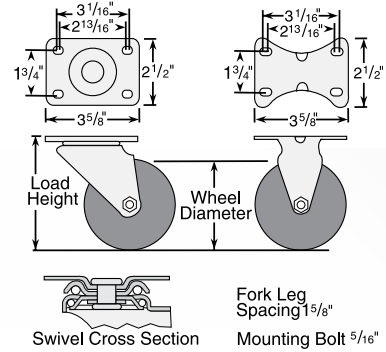

Features

- Polished 304 grade stainless steel construction handles the most punishing, corrosive conditions
- Double ball raceways for better performance and greater durability
- All component parts, including spanner bushing, axle and nut are stainless steel
- Designed to perform in the most hostile environments
- If rust is a problem... Colson stainless steel is the solution

Colson 2 Series Casters • Stainless Steel Top Plate Swivel & Rigid • Capacity to 325 lbs

Wheel Dia.	Tread Width	Capacity Each (Pounds)	Wheel Descriptions	Wheel Bearing	Swivel Top Plate Caster Models	Rigid Top Plate Caster Models	Load Height	Swivel Radius	Weight (Pounds)
3"	1 1/4"	150	Rubber HI-TECH	Plain	2.33456.42	2.33408.42	4 1/8"	3 1/8"	1 5/8
		200	Polyolefin	Delrin	2.33456.544	2.33408.544	4 1/8"	3 1/8"	1 5/8
			Polyurethane HI-TECH	Plain	2.33456.944	2.33408.944	4 1/8"	3 1/8"	1 5/8
3 1/2"	1 1/4"	225	TPE High-Temp	Prec. Ball	2.03456.414 H	2.03408.414 H	4 11/16"	3 3/8"	1 7/8
		250	Polyolefin	Delrin	2.03456.544	2.03408.544	4 11/16"	3 3/8"	1 5/8
			Polyurethane HI-TECH	Delrin	2.03456.944	2.03408.944	4 11/16"	3 3/8"	1 7/8
			Perma Rubber (Flat)	Delrin	2.03456.444	2.03408.444	4 11/16"	3 3/8"	1 3/4
	300	Thermo	Plain	2.03456.52 HT	2.03408.52 HT	4 11/16"	3 3/8"	1 5/8	
1 5/16"	210	Perma Rubber (Round)	Delrin	2.03456.564	2.03408.564	4 11/16"	3 3/8"	1 3/4	
4"	1 1/4"	250	ThermoTech	Teflon	2.04456.613 H	2.04408.613 H	5 1/8"	3 5/16"	3
			TPE High-Temp	Prec. Ball	2.04456.414 H	2.04408.414 H	5 1/8"	3 5/16"	2 1/4
		275	Polyolefin	Delrin	2.04456.544	2.04408.544	5 1/8"	3 5/16"	2 1/8
			Polyurethane HI-TECH	Delrin	2.04456.944	2.04408.944	5 1/8"	3 5/16"	2 1/8
			Perma Rubber (Flat)	Delrin	2.04456.444	2.04408.444	5 1/8"	3 5/16"	2 1/4
300	Thermo	Plain	2.04456.52 HT	2.04408.52 HT	5 1/8"	3 5/16"	2 1/4		
5"	1 1/4"	250	ThermoTech	Teflon	2.05456.613 H	2.05408.613 H	6 3/16"	4 1/16"	3
			Polyolefin	Delrin	2.05456.544	2.05408.544	6 3/16"	4 1/16"	2 5/8
		300	Polyurethane HI-TECH	Delrin	2.05456.944	2.05408.944	6 3/16"	4 1/16"	2 5/8
			TPE High-Temp	Prec. Ball	2.05456.414 H	2.05408.414 H	6 3/16"	4 1/16"	2 3/4
			Perma Rubber (Flat)	Delrin	2.05456.444	2.05408.444	6 3/16"	4 1/16"	2 3/4
	325	Thermo	Plain	2.05456.52 HT	2.05408.52 HT	6 3/16"	4 1/16"	2 3/4	
1 5/16"	250	Perma Rubber (Round)	Delrin	2.05456.564	2.05408.564	6 3/16"	4 1/16"	2 3/4	

Hollow Kingpin: available by special order only; consult factory

Wheel Selection



Fork Option

NSF Listed For Food Service Industry
Available on all models (Specify FSI; Example: 2.05456.444 FSI).

Forks Only

To order caster forks only use 1st 6 digits of model numbers (Example: 2.33456).

Caster Brake



Top Lock
(See page 96) Available on all swivel models. Not recommended for high-temp applications. Field installable (Specify **BRK1**; Example: 2.05456.944 BRK1).



Tech Lock
(See page 97) Available on 4" and 5" swivel models. Field installable (Specify **BRK2**; Example: 2.05456.544 BRK2).



Total Lock
(See page 96) Riveted design is not field installable. Locks wheel and swivel. Available on all swivel models (Specify **BRK4**; Example: 2.05456.944 BRK4).

2 Series

STAINLESS STEEL PRECISION Swivel & Rigid

Capacity up to 300 lbs each



Standard Dimensions

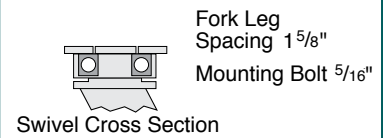
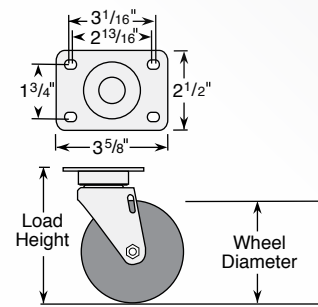

Features

- Ergonomically friendly and durable stainless steel precision bearing swivel raceway for maximum roll and swivel ease
- All component parts stainless steel to handle the most punishing, corrosive conditions
- Maintenance free, permanently sealed, precision bearing in metal housing
- 5/32" stainless steel top plate for maximum durability
- High impact strength

Typical Applications

- Typical applications include medical applications, autoclave operations or where wash down of equipment is required

Precision Raceway Advantage:

- *Quieter than conventional casters*
- *Smooth and easy turning*
- *Ergonomic: less force to push & pull*

Colson 2 Series Casters • Stainless Steel Precision • Capacity to 300 lbs

Wheel Dia.	Tread Width	Capacity Each (Pounds)	Wheel Descriptions	Wheel Bearing	Swivel Top Plate Caster Models	Rigid Top Plate Caster Models	Load Height	Swivel Radius	Weight (Pounds)
5"	1 1/4"	275	Polyolefin	Delrin	2.X5456.544	2.05408.544	6 3/16"	3 13/16"	2 5/8
			Polyurethane HI-TECH	Delrin	2.X5456.944	2.05408.944	6 3/16"	3 13/16"	2 5/8
		300	Performa Rubber (Flat)	Delrin	2.X5456.444	2.05408.444	6 3/16"	3 13/16"	2 3/4
			TPE HI-TEMP	Precision Ball	2.X5456.414 H	2.05408.414 H	6 3/16"	3 13/16"	2 1/4

Wheel Selection

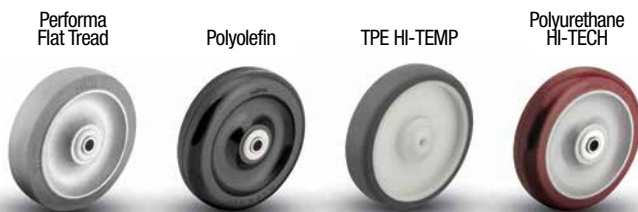

See the Performa Advantage on Page 67.

Fork Option

NSF Listed For Food Service Industry
Available on all models (Specify **FSI**;
Example: 2.X5456.544 FSI).

Forks Only
To order caster forks only, use 1st 6 digits of model numbers (Example: 2.X5456).