

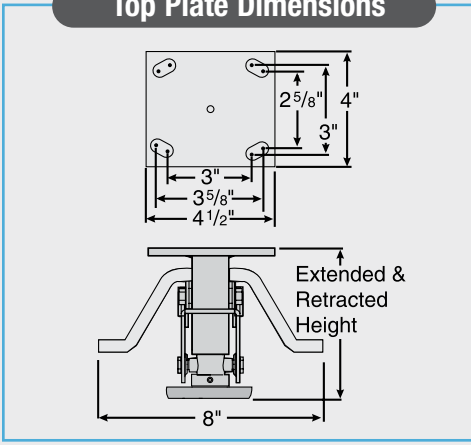

Top Plate Dimensions

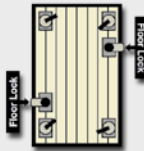

Floor Lock Brake Installation



Recommended Floor Lock mounting position using four swivel casters.

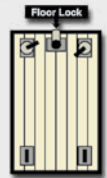

Recommended Floor Lock mounting position using two swivel and two rigid casters.

Encore Floor Lock Brakes are designed for use on level surfaces and are not recommended for use on inclined surfaces. It is important to select a floor lock model that clears the floor when retracted. To adapt a floor lock brake to your present equipment, select a model with an extended height 1/16" to 1/4" greater than the overall height of the caster.

Features

- Designed to hold portable equipment in a desired location
- Activated by toe pressure on the extension pedal or released by toe touching bar
- For best results use in pairs
- Heavy duty construction for industrial strength
- Molded rubber base pad for solid, slip resistant contact
- Adjustable by slight foot pressure for simple, instant locking
- Attractive zinc plated finish

Encore Floor Lock Specifications

| | 4" x 4-1/2" TOP PLATE MODELS (4 Series Casters) | | | |
|-------------------------------------|--|----------------------|----------------------|----------------------|
| MODEL NO. | E9.06045.04 | E9.06253.05 | E9.06045.06 | E9.06025.08 |
| Extended Height | 5 5/8" | 6 1/2" | 7 1/2" | 9 1/2" |
| Retracted Height | 4 7/8" | 5 3/4" | 6 3/4" | 8 3/4" |
| Top Plate Size | 4" x 4 1/2" | | | |
| Bolt Hole Spacing | 3" x 3" to 2 5/8" x 3 5/8" | | | |
| Bolt Hole Size | 3/8" Slotted | | | |
| Weight | 3 1/4 lbs. | 3 1/2 lbs. | 3 3/4 lbs. | 4 lbs. |
| Used with Caster Fork Model Numbers | E4.04169 E4.04168 | E4.05169 E4.05168 | E4.06169 E4.06168 | E4.08169 E4.08168 |